



PLANMECCA
Intra



The premium intraoral X-ray unit



The recognised Planmeca Intra X-ray unit design concept makes intraoral imaging easier and more trustworthy than ever before. Incorporating innovative and open-minded technical solutions, Planmeca Intra is not only easy to use, but it also delivers radiographs with outstanding clinical utility. The sophisticated concept, functional design, and superior image quality have convinced dental professionals all over the world.



50 kV



60 kV



70 kV

The high-quality construction and the advanced technological solutions make the Planmecca Intra X-ray unit the premium choice for intraoral radiography. The freely selectable exposure parameters (kV, mA, and exposure time) maximise the diagnostic value of intraoral radiography, and the pre-programmed quick settings make the operation fast and easy.

The acknowledged Planmecca design features rounded corners and smooth lines, ensuring longevity, stability, and good hygiene.

Planmecca Intra has a very high-frequency operated constant potential X-ray generator, which provides significant advantages such as:

- reduced radiation dose by up to 25% when compared to conventional AC generators
- extremely good and uniform image contrast
- absolute reproducibility of images
- improved reliability and prolonged life span of the X-ray tube
- the X-ray unit output is not affected by line voltage fluctuations.

With eight user selectable kV settings – 50, 52, 55, 57, 60, 63, 66, and 70 kV – Planmecca Intra provides tremendous freedom of choice that assures the best image contrast for any diagnostic need or anatomical condition.

50 kV: Low kV settings result in high-contrast images that are extremely useful for endodontics, apex, and bone structure diagnostics.

60 kV: Medium kV settings provide a wide greyscale for general diagnostics where a wide range of clinical information is required.

70 kV: High kV settings produce images with a long greyscale spectrum, which is useful in caries detection and periodontal diagnostics.

Variable kV assures the best image contrast



Ergonomic design for easy imaging

The unique non-symmetric design of the X-ray tube head makes aiming exceptionally easy and precise. The smooth top cover of the tube head extends seamlessly to the cone, a clever design making X-ray beam alignment faster and more accurate. The intelligent tube head and X-ray arm design facilitates positioning for an occlusal plane image.

The Planmeca Intra X-ray unit adapts to short cone (20 cm SSD) as well as to long cone (30 cm SSD) imaging techniques. Furthermore, an additional rectangular collimator can be adapted to the long cone for maximal radiation hygiene.

The extremely steady X-ray unit arm provides smooth and precise movement, providing accurate and drift-free positioning of the lightweight tube head. With the unit's versatile installation options, the reach is well sufficient for different practice designs.

Planmeca's innovative engineering ensures that the X-ray unit meets any demand within digital intraoral radiography. A simple selection of the image receptor automatically adapts the pre-programmed settings to film, imaging plate, or digital sensors.

Ultimate user-friendliness is achieved when the unit is used together with the Planmeca ProSensor digital sensor system:

- The user can easily position the sensor into patient's mouth with the TrollByte Plus sensor holder.
- The Planmeca ProSensor interconnection cable is routed inside the X-ray unit arm, which results in a clear and clean working area with no interfering cables.
- The imaging parameters (kV, mA, exposure time) are transferred to the imaging software to be recorded with the patient's images.



The imaging parameters are selected from the intuitive control panel. The unit is pre-programmed with 66 quick settings for different exposure value combinations. Imaging parameters are automatically retrieved according to the selected exposure region and the diagnostic need:

- periapical imaging of the incisors, premolars/canines, and molars, separately for upper and lower jaw
- upper and lower occlusal plane imaging
- bitewing imaging
- endodontic imaging.

The control panel displays the selected values. They can be manually adjusted, if needed. The operator can also store the altered setting in the quick setting memory.

There are distinct, optimally adjusted settings for adults and children.

The selection of the imaging mode allows a rapid transformation of all pre-programmed settings when changing to a new image receptor type. There are predefined imaging modes for film, imaging plate, and digital sensor. This allows very fast and trouble-free transition to new imaging technologies without any reprogramming of the quick settings.

Planmeca Intra features a smart control for maintaining the constant darkness of the radiograph whenever imaging conditions change. The unit has eleven density steps that adjust all quick settings if, for example,

the user decides to change the film type or wants to use the short cone technique instead of the long cone technique.

The self-diagnostic control system monitors all unit functions and displays error messages in case of abnormal operation. The control system assists in the correct use of the unit and speeds up technical service.

After each exposure, the automatic duty cycle control displays an overheat countdown ensuring reliable long-term operation of the X-ray tube.

The unit is delivered with a hand held control panel or optionally a wall-mounted remote exposure station.



PLANMECA
ProSensor

PLANMECA
ProSensor

PLANMECA
ProSensor

Integrated digital sensor

The Planmeca ProSensor digital radiography system is a major contribution to increased workflow. The dental team can focus on the patient, since the imaging procedure includes a minimum amount of steps.

Planmeca ProSensor is designed, first and foremost, with durability in mind. The sensor cable is a result of careful design, technology and testing. Hermetically sealed,

the sensor can be fully immersed in disinfectant for effective infection control and prevention. The intelligent housing design with rounded edges and extensive active imaging area maximises both patient comfort and imaging performance.

Placing the sensor and the control box conveniently at the Planmeca Intra X-ray unit allows a clear and

well-organised working environment without interfering cables.

After the exposure, the image is displayed on the screen within seconds. Instantaneous viewing dramatically shortens the time needed for an intraoral X-ray examination, when compared to imaging plates or conventional film.





Standard wall mount

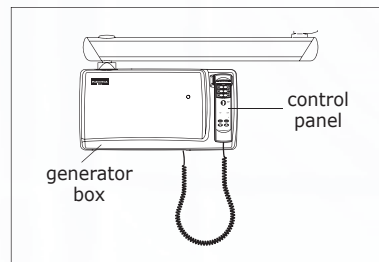

Remote control panel

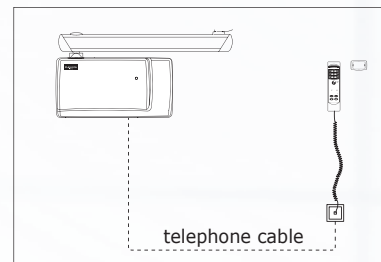

Fixed control panel with double exposure button

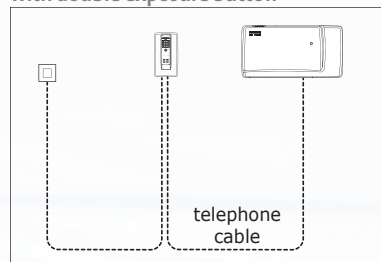

Planmecca dental unit mount

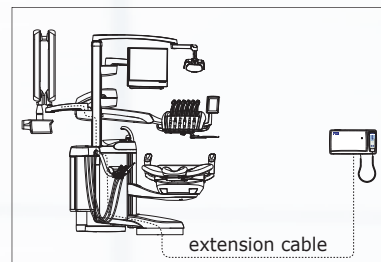

Single stud mount

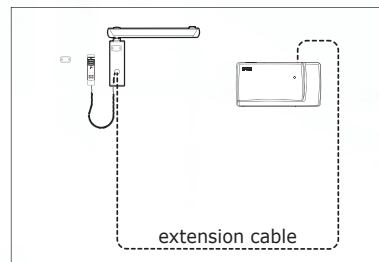

Ceiling mounting (with Planmecca Delight operating light)

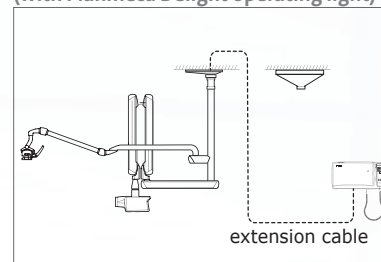

Floor mounting column

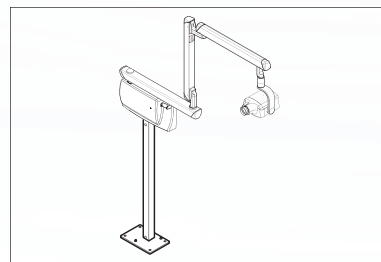

Mobile stand

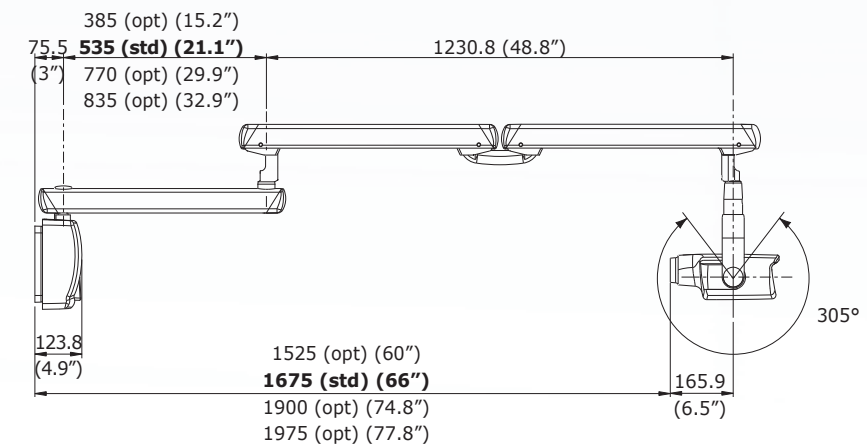
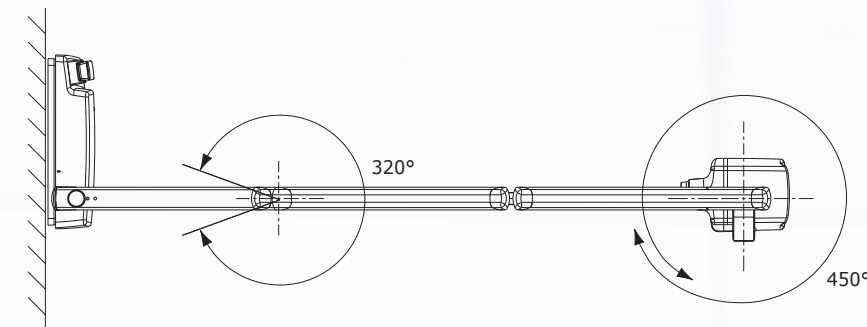
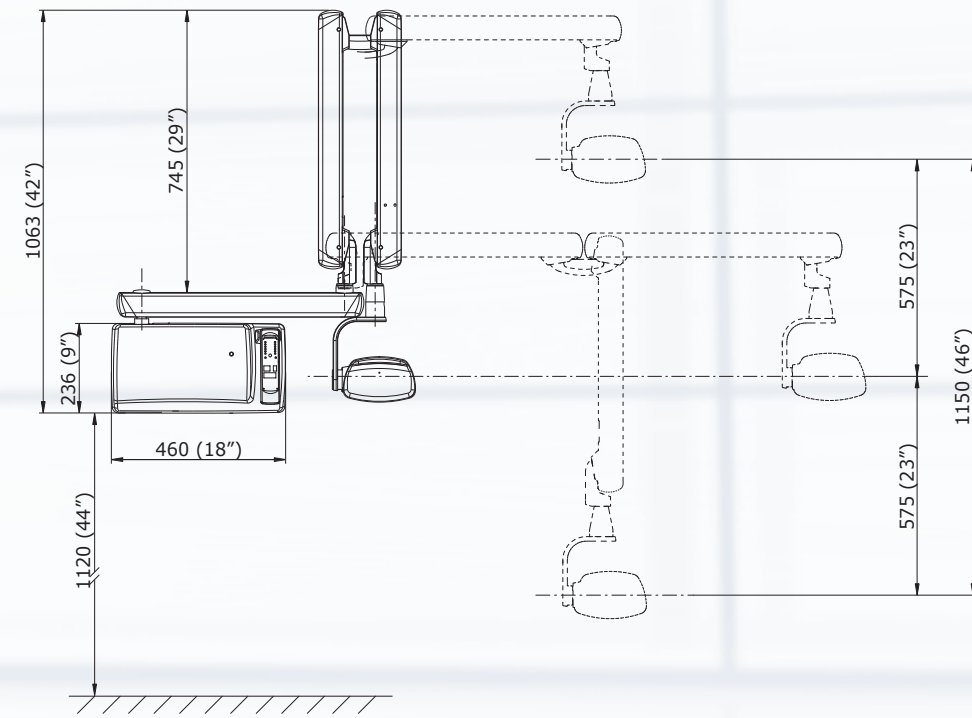
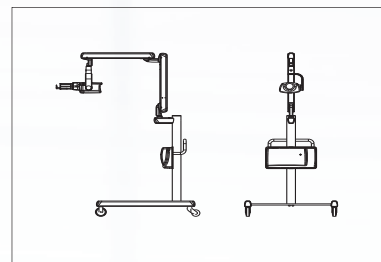

Planmeca Romexis software

Planmeca Romexis is a complete dental imaging software, including all dental imaging modalities: intraoral, panoramic, cephalometric, 3D imaging, dental tomography as well as intraoral video and still camera imaging. With a complete set of tools for image viewing, enhancement, measurements, and annotations, Planmeca Romexis also improves the diagnostic value of radiographs. Printing, image import and export, and DICOM functionalities are also included.

Planmeca Romexis platform fully integrates digital imaging with the patient's other clinical data. The system provides direct image capture from Planmeca's X-ray equipment, and interfaces with 3rd party devices via TWAIN. Together with Planmeca's X-ray equipment, Planmeca Romexis provides a unique safety feature especially useful for teaching environment: the X-ray image capture is inhibited until the supervisor has approved the student's image capture request.

Planmeca Romexis computer recommendations

	Planmeca Romexis client workstation	Planmeca Romexis server
Processor	1 GHz	2 GHz
RAM	1 GB	2 GB
Hard disk space	40 GB	160 GB
Monitor	1280 x 1024	1024 x 768
Peripherals	CD R/W or DVD R/W drive	CD R/W or DVD R/W drive
Backup medium	None necessary	DAT or equivalent
Operating system	Windows XP Windows 2003 Server Windows Vista Windows 7 Mac OS X	Windows XP Pro Windows 2003 Server Windows Vista Windows 7
Other	Java platform (Java Virtual Machine 1.6 or later)	Java platform (Java Virtual Machine 1.6 or later)

The disk space requirements are determined by digital images. Thus the space requirements vary, but a rough estimate is in the order of 1 MB per 2D X-ray image, 7-9 MB per extraoral image, depending on a variety of image specific factors, and 250 MB per 3D image.

It is recommended to use the same computer as an application server and as a database server. If Planmeca Romexis server computer is also used for client activities, the hardware should meet both client and server specifications.

These specifications are recommended minimum requirements. Not meeting them may lead to degraded performance.

DICOM compatibility

- Media Storage – saving images into removable DICOM media
- Print – printing images on film or paper with a DICOM medical printer
- Storage – saving images into DICOM image archive
- Query/ Retrieve – importing digital images from DICOM image archive
- Worklist – importing a patient list from DICOM patient management
- Storage Commitment – confirmation of a successful image storage

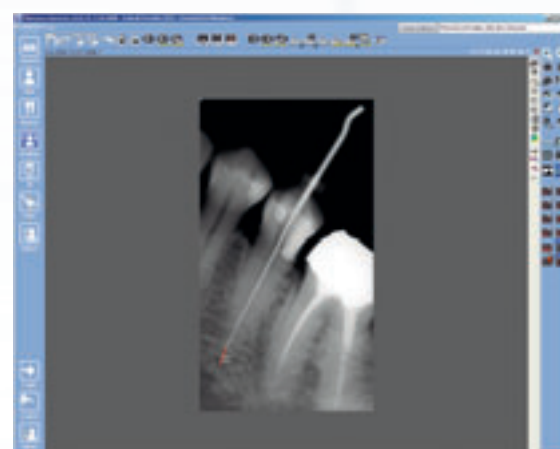
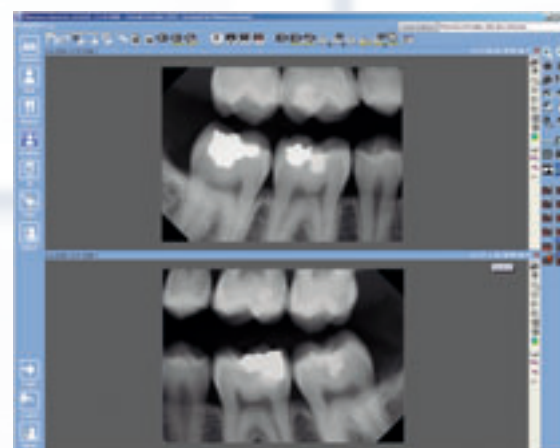
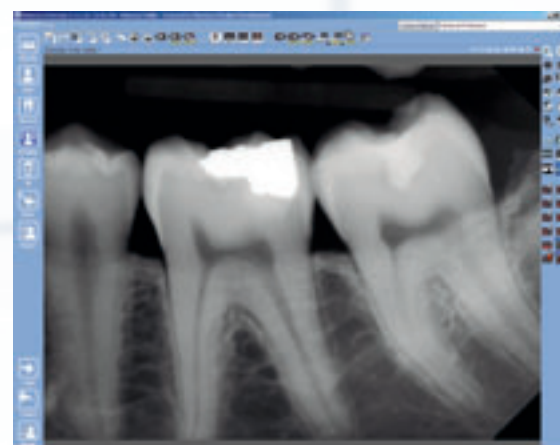

Planmeca Intra

Generator	Constant potential, microprocessor controlled, high frequency 66 kHz	
X-ray tube	Toshiba D-0711 SB	
Focal spot	0.7 mm x 0.7 mm	
Cone diameter	60 mm (2.36 in.), rectangular 36 x 45 mm (1.38 x 1.77 in.)	
Filtration	min. 2 mm Al	
Anode voltage	50, 52, 55, 57, 60, 63, 66, 70 kV	
kV rise time	8 ms	
Anode current	2, 3, 4, 5, 6, 7, 8 mA DC	
Exposure times	0.01-3.2 s, 26 steps	
SSD (Standard/Long)	200 mm (8 in.) / 300 mm (12 in.)	
Line Voltage	100 / 110-115 / 220-240 V ±10%	
Fusing	15 AT / 8 AT	
Duty cycle	1:15, automatic control	
Weight	Total	23 kg (51 lbs)
	Tube head	4.5 kg (10 lbs)
Colour	White (RAL 9016)	

Planmeca ProSensor

	Size 0	Size 1	Size 2
Sensor size	33.6 x 23.4 mm (1.33 x 0.92 in.)	39.7 x 25.05 mm (1.56 x 0.99 in.)	44.1 x 30.4 mm (1.74 x 1.2 in.)
Active area	25.5 x 18.9 mm (1.0 x 0.74 in.)	31.5 x 20.7 mm (1.24 x 0.81 in.)	36 x 26.1 mm (1.42 x 1.03 in.)
Number of pixels	850 x 629	1050 x 690	1200 x 870
Physical pixel size	15 x 15 µm	15 x 15 µm	15 x 15 µm
Pixel size	30 x 30 µm	30 x 30 µm	30 x 30 µm
Theoretical resolution	33 lp/mm	33 lp/mm	33 lp/mm
Resolution	17 lp/mm	17 lp/mm	17 lp/mm
Interface	USB or Ethernet		
View delay	<5 s	<5 s	<5 s



Planmeca Oy designs and manufactures a full line of high technology dental equipment, including dental care units, panoramic and intraoral X-ray units, and digital imaging products. Planmeca Oy, the parent company of the Finnish Planmeca Group, is strongly committed to R&D, and is the largest privately held company in the field.



Planmeca Oy
 Asentajankatu 6 | 00880 Helsinki | Finland
 tel. +358 20 7795 500 | fax +358 20 7795 555
 sales@planmeca.com | www.planmeca.com

Images may contain optional items not included in standard delivery. Available configurations and features may have country or area specific variations. Some products displayed above may not be available in all countries or areas. Rights for changes reserved.